

Low Pressure Sandwich Valves

CONTACT INFORMATION

USA Headquarters

Dynex/Rivett Inc.
770 Capitol Drive
Pewaukee, WI 53072 U.S.A.
Tel: 262-691-2222
FAX: 262-691-0312
E-mail: sales@dynexhydraulics.com

Power Units & Systems

Dynex/Rivett Inc.
54 Nickerson Road
Ashland, MA 01721 U.S.A.
Tel: 508-881-5110
FAX: 508-881-6849
E-mail: ashland@dynexhydraulics.com

European Sales

Dynex/Rivett Inc.
Unit C5 Steel Close, Little End Road, Eaton Socon,
Huntingdon, Cambs. PE19 8TT United Kingdom
Tel: +44 (0) 1480 213980
FAX: +44 (0) 1480 405662
E-mail: sales@dynexhydraulics.co.uk

**For more information
visit our web site:
www.dynexhydraulics.com**

BROCHURE NOTES:

Consult the Dynex sales department for a review of any application which requires operating above the rated flows or pressures, or higher than normal operating temperatures.

Specifications shown were in effect when published. Since errors or omissions are possible, contact your sales representative for the most current specifications before ordering. Dynex reserves the right to discontinue or change designs at any time without incurring any obligation.



LOW PRESSURE SANDWICH VALVES

Low Pressure Valves Save Space and Reduce Weight

These sandwich valves mount under directional controls with standard N.F.P.A. (CETOP) patterns.

Mounting/Maximum Flow

N.F.P.A. D03 (CETOP 3) Pattern:

6 U.S. gpm (23 L/min);

N.F.P.A. D05 (CETOP 5) Pattern:

12 U.S. gpm (45 L/min);

D05H Size, N.F.P.A. D05 (CETOP 5) Pattern^②, High Flow:

20 U.S. gpm (76 L/min)

Rated Pressure

3000 psi (210 bar)

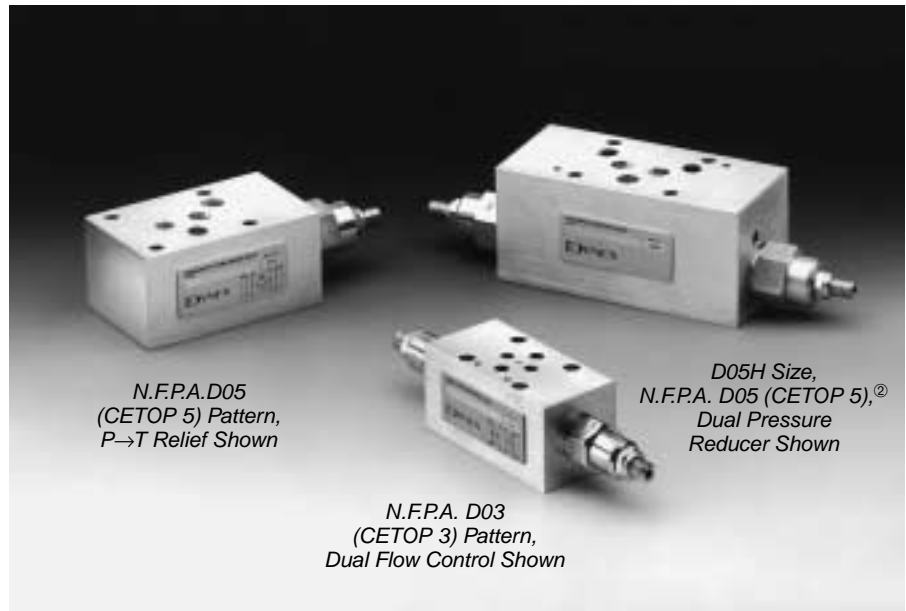

SANDWICH VALVE SELECTION

Function	D03 Pattern		D05 Pattern		D05H Size ^②	
	Valve Model	Cartridge	Valve Model	Cartridge	Valve Model	Cartridge
NON-COMPENSATED FLOW CONTROLS						
Inlet Pressure Flow Control	S8620-D03-P-V-21	56*8721	S8620-D05-P-V-21	56*8731	—	—
Dual Flow Control	S8620-D03-AB-V-21	56*8701 ^①	S8620-D05-AB-V-21	56*8711 ^①	S8620-D05H-AB-V-20	56*8713 ^①
“A” Port Flow Control	S8620-D03-A-V-21	56*8701	S8620-D05-A-V-21	56*8711	S8620-D05H-B-V-20	56*8713
“B” Port Flow Control	S8620-D03-B-V-21	56*8701	S8620-D05-B-V-21	56*8711	S8620-D05H-B-V-20	56*8713
PRESSURE COMPENSATED FLOW CONTROLS						
Inlet Pressure Flow Control	S8622-D03-P-V-20	56*8706	S8622-D05-P-V-20	56*8716	—	—
Dual Flow Control	S8622-D03-AB-V-20	56*8706 ^①	S8622-D05-AB-V-20	56*8716 ^①	S8622-D05H-AB-V-20	56*8718 ^①
“A” Port Flow Control	S8622-D03-A-V-20	56*8706	S8622-D05-A-V-20	56*8716	S8622-D05H-A-V-20	56*8718
“B” Port Flow Control	S8622-D03-B-V-20	56*8706	S8622-D05-B-V-20	56*8716	S8622-D05H-B-V-20	56*8718
CHECK VALVES						
Inlet Pressure Check	S8640-D03-P-V-20	56*8671	S8640-D05-P-V-20	56*8681	—	—
Dual Pilot Operated Check	S8642-D03-AB-V-21	56*8652 ^①	S8642-D05-AB-V-21	56*8662 ^①	S8642-D05H-AB-V-21	56*8662 ^①
“A” Port Pilot Operated Check	S8642-D03-A-V-21	56*8652	S8642-D05-A-V-21	56*8662	S8642-D05H-A-V-21	56*8662
“B” Port Pilot Operated Check	S8642-D03-B-V-21	56*8652	S8642-D05-B-V-21	56*8662	S8642-D05H-B-V-21	56*8662
RELIEF VALVES						
“P” to “T” Relief	S8820-D03-PT-V-20	56*8501	S8820-D05-PT-V-20	56*8511	S8820-D05H-PT-V-20	56*8511
Dual Crossport Relief	S8820-D03-AB-V-20	56*8501 ^①	S8820-D05-AB-V-20	56*8511 ^①	—	—
“A” to “B” Relief	S8820-D03-A-V-20	56*8501	S8820-D05-A-V-20	56*8511	—	—
“B” to “A” Relief	S8820-D03-B-V-20	56*8501	S8820-D05-B-V-20	56*8511	—	—
COUNTERBALANCE VALVES						
Dual Counterbalance	S8831-D03-AB-V-20	56*8621	S8831-D05-AB-V-20	56*8631 ^①	S8831-D05H-AB-V-20	56*8631 ^①
“A” Port Counterbalance	S8831-D03-A-V-20	56*8621	S8831-D05-A-V-20	56*8631	S8831-D05H-A-V-20	56*8631
“B” Port Counterbalance	S8831-D03-B-V-20	56*8621	S8831-D05-B-V-20	56*8631	S8831-D05H-B-V-20	56*8631
PRESSURE REDUCING VALVES						
Inlet Pressure Reducer	S8837-D03-P-V-20	56*8601	S8837-D05-P-V-20	56*8611	—	—
Dual Pressure Reducer	S8837-D03-AB-V-20	56*8601 ^①	S8837-D05-AB-V-20	56*8611 ^①	S8837-D05H-AB-V-20	56*8611 ^①
“A” Port Pressure Reducer	S8837-D03-A-V-20	56*8601	S8837-D05-A-V-20	56*8611	S8837-D05H-A-V-20	56*8611
“B” Port Pressure Reducer	S8837-D03-B-V-20	56*8601	S8837-D05-B-V-20	56*8611	S8837-D05H-B-V-20	56*8611

① Two cartridges required for these models. ② D05 pattern with auxiliary “X” and “Y” ports.

LOW PRESSURE SANDWICH VALVES

SANDWICH VALVE ADVANTAGES

These valves save space, reduce weight and provide greater flexibility in locating valves.

Controlling components can be placed right at the directional control valve, providing a compact assembly.

This modular design approach requires less piping and fittings, reducing machine costs and assembly time, and limiting potential system leakage.

DIMENSIONS

The installation drawing applies to all valve sizes. Refer to the appropriate table for variable dimensions.

Dimensions "F" and "G" establish the location of the standard mounting pattern on the body.

The dimension for any plug on either end of a valve is denoted by dimension "C". Where no dimension "C" is shown in the table, the valve has no plug(s).

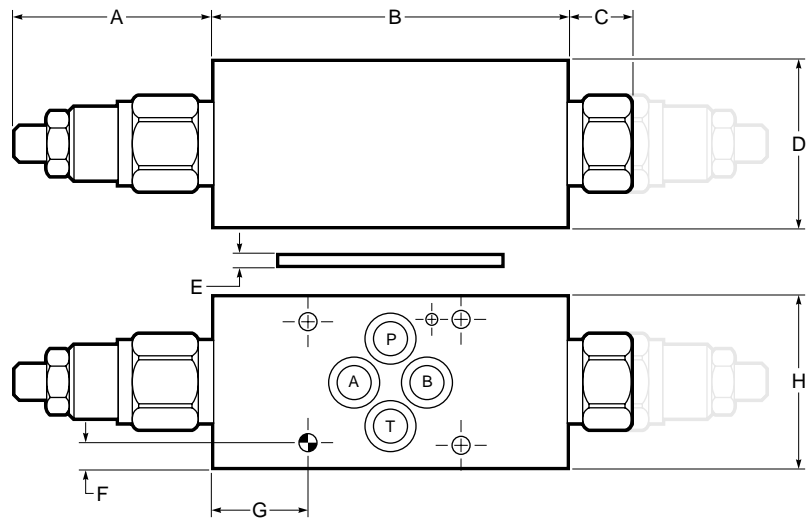

The last column in each table indicates cartridge location (see the footnote below the tables). In the installation drawing, the configuration for a second cartridge is shown printed in gray.

The overall length of a one-cartridge valve is the sum of dimension "A" (cartridge) plus "B" (body) plus "C" (plug). The length of a two-cartridge valve is the sum of "A" plus "B" plus "A" (second cartridge).

D03 PATTERN VALVES

Port o-rings and seal plates are included with valves.

Mounting bolts must be ordered separately and are shown in the table below.

MOUNTING KITS

Item: Part Number	Description
One-Station Kit: 94*0026	Four Studs, Four Nuts 10-24 U.N.C. Threaded x 9 inches (228,9 mm)
Four-Station Kit: 94*0027	Four Studs, 16 Nuts 10-24 U.N.C. Threaded x 36 inches (914,4 mm)
Bulk Kit: 94*0024	10 Studs, 50 Nuts
Nut Kit: 94*0024	50 Nuts Only
D03-10 Design: P25-BK-40	Kit to Mount One Valve

VARIABLE DIMENSIONS – D03 PATTERN

Valve Model	A	B	C	D	E	F	G	H	Location ^① of Cartridge(s)
S8620-D03-P-V-21	2.03	2.39	—	1.70	.06	.23	.28	1.75	B
S8620-D03-AB-V-21	2.03	3.62	—	1.70	.06	.23	.96	1.75	A + B
S8620-D03-A-V-21	2.03	3.62	.72	1.70	.06	.23	.96	1.75	A
S8620-D03-B-V-21	2.03	3.62	.72	1.70	.06	.23	.96	1.75	B
S8622-D03-P-V-20	2.03	2.39	—	1.70	.06	.23	.28	1.75	B
S8622-D03-AB-V-20	2.03	3.62	—	1.70	.06	.23	.96	1.75	A + B
S8622-D03-A-V-20	2.03	3.62	.72	1.70	.06	.23	.96	1.75	A
S8622-D03-B-V-20	2.03	3.62	.72	1.70	.06	.23	.96	1.75	B
S8640-D03-P-V-20	.72	2.39	—	1.70	.06	.23	.28	1.75	B
S8642-D03-AB-V-21	.50	4.88	—	1.70	.06	.23	1.60	1.75	A + B
S8642-D03-A-V-21	.50	4.88	.50	1.70	.06	.23	1.60	1.75	A
S8642-D03-B-V-21	.50	4.88	.50	1.70	.06	.23	1.60	1.75	B
S8820-D03-PT-V-20	1.97	2.58	—	1.70	.06	.23	.28	1.75	B
S8820-D03-AB-V-20	1.97	3.62	—	1.70	.06	.23	.96	1.75	A + B
S8820-D03-A-V-20	1.97	3.62	.72	1.70	.06	.23	.96	1.75	A
S8820-D03-B-V-20	1.97	3.62	.72	1.70	.06	.23	.96	1.75	B
S8831-D03-AB-V-20	1.28	4.88	—	1.70	.06	.23	1.60	1.75	A + B
S8831-D03-A-V-20	1.28	4.88	.50	1.70	.06	.23	1.60	1.75	A
S8831-D03-B-V-20	1.28	4.88	.50	1.70	.06	.23	1.60	1.75	B
S8837-D03-P-V-20	1.81	2.94	-	1.70	.06	.23	.97	1.75	A
S8837-D03-AB-V-20	1.81	4.88	-	1.70	.06	.23	.97	1.75	A + B
S8837-D03-A-V-20	1.81	4.88	.50	1.70	.06	.23	1.60	1.75	A
S8837-D03-B-V-20	1.81	4.88	.50	1.70	.06	.23	1.60	1.75	B

① Letter shows location of cartridge(s). For example, "A" indicates a single cartridge on Port "A" end of valve, "A + B" indicates a cartridge on both ends of valve.

LOW PRESSURE SANDWICH VALVES

D05 PATTERN VALVES

Port o-rings and seal plates, where required, are included with valves.

The height of the body (dimension "D") determines the correct kit to mount one valve. Valves with dimension "D" equal to 1.94 inches (49,3 mm) use Kit P11-BK-44; those with "D" equal to 2.44 inches (62,0 mm) use Kit P11-BK-52.

MOUNTING KITS

Item: Part Number	Description
One-Station Kit: 94*0036	Four Studs, Four Nuts .250-20 U.N.C. Threaded x 9 Inches (228,9 mm)
Four-Station Kit: 94*0037	Four Studs, 16 Nuts .250-20 U.N.C. Threaded x 36 Inches (914,4 mm)
Bulk Kit: 94*0033	10 Studs, 50 Nuts
Nut Kit: 94*0034	50 Nuts Only
P11-BK-44	Kit to Mount One Valve
P11-BK-52	Kit to Mount One Valve

D05H SIZE VALVES

Port o-rings and seal plates, where required, are included with valves.

The height of the body (dimension "D") determines the correct kit to mount one valve. Valves with dimension "D" equal to 1.94 inches (49,3 mm) use Kit P22-BK-48; those with "D" equal to 2.44 inches (62,0 mm) use Kit P22-BK-56; those with "D" equal to 2.94 inches (74,7 mm) use Kit P22-BK-64.

MOUNTING KITS

Item: Part Number	Description
One-Station Kit: 94*0036	Four Studs, Four Nuts .250-20 U.N.C. Threaded x 9 Inches (228,9 mm)
Four-Station Kit: 94*0037	Four Studs, 16 Nuts .250-20 U.N.C. Threaded x 36 Inches (914,4 mm)
Bulk Kit: 94*0033	10 Studs, 50 Nuts
Nut Kit: 94*0034	50 Nuts Only
P11-BK-48	Kit to Mount One Valve
P11-BK-56	Kit to Mount One Valve
P11-BK-64	Kit to Mount One Valve

VARIABLE DIMENSIONS – D05 PATTERN

Valve Model	A	B	C	D	E	F	G	H	Location ^① of Cartridge(s)
S8620-D05-P-V-21	2.41	3.00	—	2.44	—	.34	.44	2.50	A
S8620-D05-AB-V-21	2.41	4.38	—	1.94	.05	.34	1.06	2.50	A + B
S8620-D05-A-V-21	2.41	4.38	.65	1.94	.05	.34	1.06	2.50	A
S8620-D05-B-V-21	2.41	4.38	.65	1.94	.05	.34	1.06	2.50	B
S8622-D05-P-V-20	2.41	3.00	—	2.44	—	.34	.44	2.50	A
S8622-D05-AB-V-20	2.41	4.38	—	1.94	.05	.34	1.06	2.50	A + B
S8622-D05-A-V-20	2.41	4.38	.65	1.94	.05	.34	1.06	2.50	A
S8622-D05-B-V-20	2.41	4.38	.65	1.94	.05	.34	1.06	2.50	B
S8640-D05-P-V-20	.66	3.00	—	2.44	②	.34	.44	2.50	A
S8642-D05-AB-V-21	.66	5.12	—	1.94	②	.34	1.50	2.50	A + B
S8642-D05-A-V-21	.66	5.12	.66	1.94	②	.34	1.50	2.50	A
S8642-D05-B-V-21	.66	5.12	.66	1.94	②	.34	1.50	2.50	B
S8820-D05-PT-V-20	2.09	4.00	—	1.94	②	.34	1.44	2.50	A
S8820-D05-AB-V-20	2.09	3.62	—	2.44	②	.34	.75	2.50	A + B
S8820-D05-A-V-20	2.09	3.62	.66	2.44	②	.34	.75	2.50	A
S8820-D05-B-V-20	2.09	3.62	.66	2.44	②	.34	.75	2.50	B
S8831-D05-AB-V-20	1.66	5.12	—	1.94	②	.34	1.50	2.50	A + B
S8831-D05-A-V-20	1.66	5.12	.66	1.94	②	.34	1.50	2.50	A
S8831-D05-B-V-20	1.66	5.12	.66	1.94	②	.34	1.50	2.50	B
S8837-D05-P-V-20	2.09	3.31	—	2.44	②	.34	.75	2.50	A
S8837-D05-AB-V-20	2.09	5.12	—	1.94	②	.34	1.50	2.50	A + B
S8837-D05-A-V-20	2.09	5.12	.66	1.94	②	.34	1.50	2.50	A
S8837-D05-B-V-20	2.09	5.12	.66	1.94	②	.34	1.50	2.50	B

① Letter shows location of cartridge(s). For example, "A" indicates a single cartridge on Port "A" end of valve, "A + B" indicates a cartridge on both ends of valve.

② No seal plate required.

VARIABLE DIMENSIONS – D05H SIZE

Valve Model	A	B	C	D	E	F	G	H	Location ^① of Cartridge(s)
S8620-D05H-AB-V-21	2.63	6.62	—	2.94	.05	.34	2.25	2.50	A + B
S8620-D05H-A-V-21	2.63	6.62	.94	2.94	.05	.34	2.25	2.50	A
S8620-D05H-B-V-21	2.63	6.62	.94	2.94	.05	.34	2.25	2.50	B
S8622-D05H-AB-V-20	2.63	6.62	—	2.94	.05	.34	2.25	2.50	A + B
S8622-D05H-A-V-20	2.63	6.62	.94	2.94	.05	.34	2.25	2.50	A
S8622-D05H-B-V-20	2.63	6.62	.94	2.94	.05	.34	2.25	2.50	B
S8642-D05H-AB-V-21	.64	5.37	—	2.44	.05	.34	1.62	2.50	A + B
S8642-D05H-A-V-21	.64	5.37	.64	2.44	.05	.34	1.62	2.50	A
S8642-D05H-B-V-21	.64	5.37	.64	2.44	.05	.34	1.62	2.50	B
S8820-D05H-PT-V-20	1.40	4.31	.66	1.94	②	.34	1.44	2.50	A
S8831-D05H-AB-V-20	1.64	5.37	—	2.44	.05	.34	1.62	2.50	A + B
S8831-D05H-A-V-20	1.64	5.37	.64	2.44	.05	.34	1.62	2.50	A
S8831-D05H-B-V-20	1.64	5.37	.64	2.44	.05	.34	1.62	2.50	B
S8837-D05H-AB-V-20	2.08	5.37	—	2.44	.05	.34	1.62	2.50	A + B
S8837-D05H-A-V-20	2.08	5.37	.64	2.44	.05	.34	1.62	2.50	A
S8837-D05H-B-V-20	2.08	5.37	.64	2.44	.05	.34	1.62	2.50	B

① Letter shows location of cartridge(s). For example, "A" indicates a single cartridge on Port "A" end of valve, "A + B" indicates a cartridge on both ends of valve.

② No seal plate required.

LOW PRESSURE SANDWICH VALVES

SANDWICH VALVE FUNCTIONS

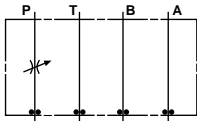

Inlet Pressure Flow Control

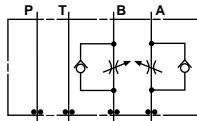

Dual Flow Control

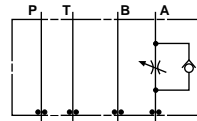

"A" Port Flow Control

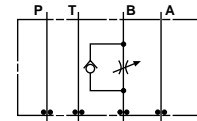

"B" Port Flow Control

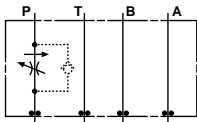

Pressure Compensated Flow Control

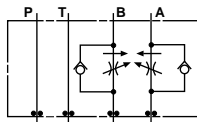

Pressure Compensated Dual Flow Control

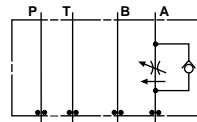

Pressure Compensated "A" Port Flow Control

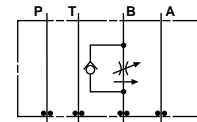

Pressure Compensated "B" Port Flow Control

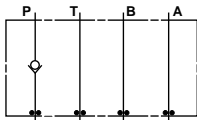

Inlet Pressure Check

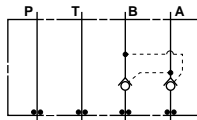

Dual Pilot Operated Check

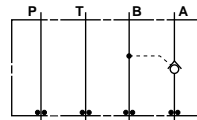

"A" Port Pilot Operated Check

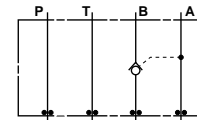

"B" Port Pilot Operated Check

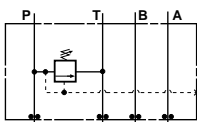

"P" to "T" Relief

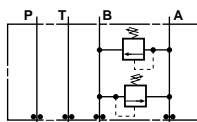

Dual Crossport Relief

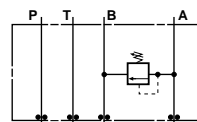

"A" to "B" Relief

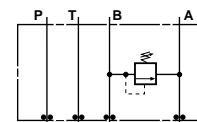

"B" to "A" Relief

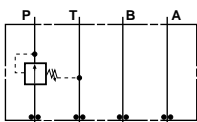

Inlet Pressure Reducer

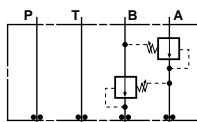

Dual Pressure Reducer

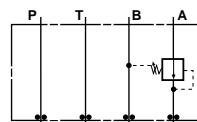

"A" Port Pressure Reducer

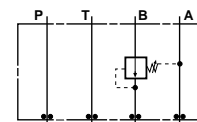

"B" Port Pressure Reducer

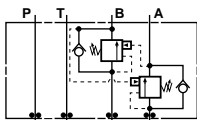

Dual Counterbalance

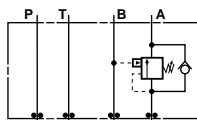

"A" Port Counterbalance

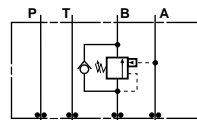

"B" Port Counterbalance

NOTE:
"Meter out" function. For "meter in," turn valve over.